

ICE MAKER

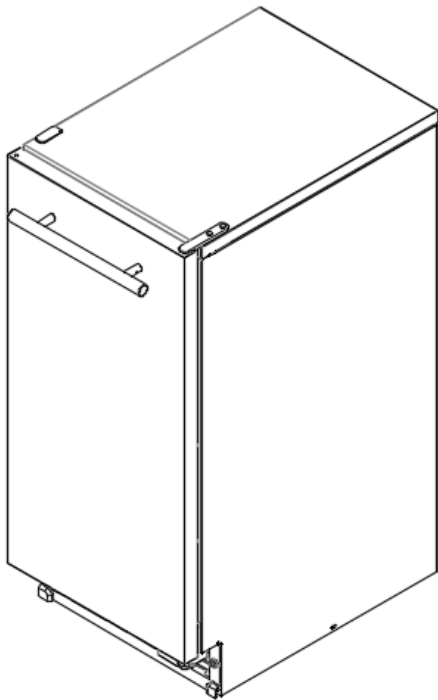

User's Manual

Read this manual carefully before using the product. Keep the manual in a safe place after reading it, for future reference.

IU-0090-AN
IU-0090-ANP
IU-0090-ANA
IU-0090-ANAP

- Where the supply voltage is different.
- This product is designed for indoor use only.
- The appearance, design, color, and parts of the product are subject to change without notice.



Table of Contents

1. Overview	3
2. Unpacking	4
3. Installation Specifications	6
4. Gravity Drain Model	8
5. Drain Pump Model	9
6. Installation of the Product	10
7. Guide to Operating the Ice Maker	14
8. Maintenance Schedule	18
9. Specifications	19
10. Error Type	20
11. Circuit Diagram	21
12. Troubleshooting Guide	22

1. Overview

The functions and specifications stated in this manual and on the website may be changed at anytime without prior notice.

The manual has **WARNING** and **CAUTION** marks. The information described in the boxes is important for the safe and efficient installation of the ice maker. Two types of cases may be found during installation.

CAUTION

If the instructions are not observed, a situation that may result in minor injury and/or damage to the product may be created.

WARNING

If the instructions are not observed, serious injury or death may result.

Thank you for purchasing the Ice Maker(Drain pump is optional). The product is a built-in type of ice maker and is designed for use at home. The product produces transparent ice of the highest quality.

Proper installation of the ice maker is of the utmost importance. The product should be installed by a qualified technician or installer.

Before installing the product, read the user's installation manual in full. The manual contains detailed instructions to be observed during installation. If you read this manual carefully, you will be able to install the product safely, without any problems or difficulty. If you have any questions about its installation.

Review the warranty card included in this manual and, if service is required, refer to the warranty card.

Important Information : When designing or manufacturing the ice maker, safety matters and functions are accorded the utmost importance. This ice maker is designed according to the **ETL Safety/UL** standard. The company does not bear any responsibility or liability for products that are subsequently modified or installed with parts not supplied or approved, or not used in the correct way. The company may modify or improve the design at anytime. The specifications and design may be changed without prior notice.

2. Unpacking

After removing the packing material, check the appearance of the ice maker for possible defects or irregularity.

If the product shows any irregularity in its appearance, contact your local distributor.

All the packing material (straps, box, Styrofoam, and wood, etc) should not be left within reach of children and should be disposed of.

For safety, the product should be installed and used with caution and in accordance with the User's Manual.

Incorrect installation or careless use of the product may damage or injure the environment, humans, animals, and/or materials and property. The manufacturer does not bear any responsibility for the aforesaid damage or injury.

This ice maker performs best at an ambient temperature of 50~75°F and water temperature of 50°F.

The ice maker should be installed in a controlled indoor environment, but it should NOT be installed near a heat source such as a heater, stove, or dish washer.

Outside air

The ice maker takes in ambient air through the left portion of the kick plate/grill and expels hot air through the right portion of the same kick plate/grill. If any material is placed in front of the kick plate/grill, the air flow will be restricted, resulting in reduced performance and, in the worst case, malfunction. The ice maker should be operated within an ambient temperature range of 50°F to 100°F.

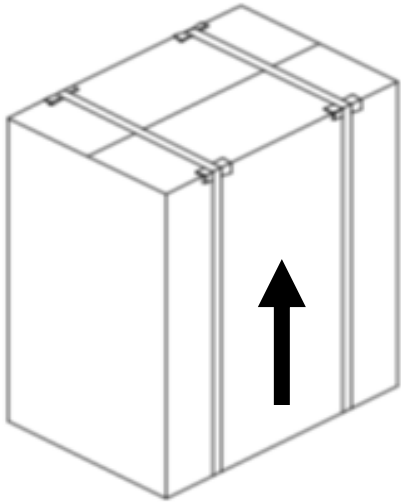

Photo. 1

Water supply

The ice maker requires a continuous supply of potable water at a pressure of 20–80psi

Water quality

There is no such thing as “perfectly pure” water. All kinds of water, including tap water, contains impurities. Rainwater absorbs impurities from the atmosphere and/or when it passes through soil. Some impurities consist of solid particles called suspended solids and are filtered through micro filters. Any remaining impurities, which cannot be filtered because they are chemically combined with water molecules, are called dissolved solids.

The mineral content of the ice produced by this product is reduced compared to the content in the water before conversion into ice. Water containing a low level of impurities is rapidly frozen. The reason for this is that the impurities elevate the temperature of water. Through such an action, most of the impurities condensed in the water–tank of the ice maker form what’s known as scale. This icemaker reduces the mineral level by circulating water during the harvest cycle (the excessive quantity is removed through an outlet tube).

Each cycle requires about 0.64 quarter (0.6ℓ) of water. For each quarter, about 0.5 quarter is used in rinsing the water tank and the remainder is removed through the outlet pipe.

In this process, some impurities unavoidably remain and may accumulate on the internal parts of the ice maker, forming abnormal ice pieces. If a large quantity of mineral scale accumulates, the lifespan of the ice maker may be reduced.

For best operation of the ice maker, impurities and minerals should be removed by washing with ice machine cleaner periodically. The method of cleaning the ice maker is described on page 18. In general, it is best to use filtered water. Water filtration may remove not only bad odor but also scale.

Water softener is not recommended because it exchanges minerals. If the hardness of the water is very high, using a water softener may lead to opaque pieces of ice.

If you have any questions about the purity of your water, contact a water treatment expert in your area.

This product was thoroughly cleaned at the factory. However, it is advised that you check the cleanliness of the machine before use and maintain its cleanliness during use.

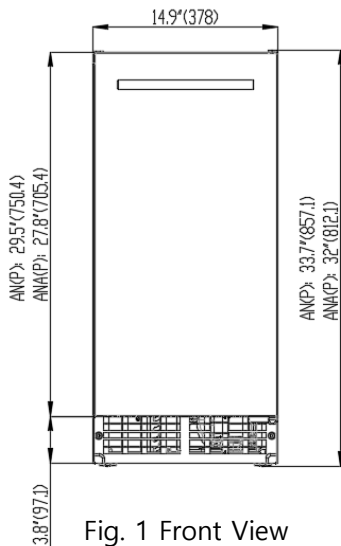

Fig. 1 Front View

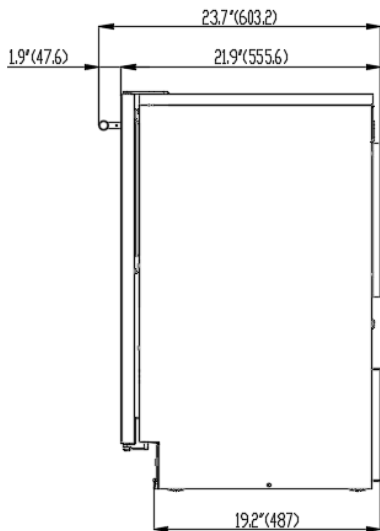

Fig. 2 Side View

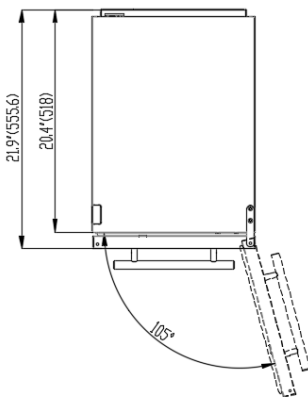

Fig. 3 Top View

3. Installation Instructions

Space requirements

When installing the ice maker, check that the electric power, and piping position are correct. Refer to the installation specifications and drawings shown on pages 7 and 8. Figures 4, 5, 6 and 7 show the entire dimensions of the product.

This product comes standard with a gravity drain connection that requires a drain line to be run from the drain fitting at the back of the product to appropriate water drain. The optional drain pump can be installed to pump water to a higher drainage point, such as a neighboring sink. Refer to the specifications shown on pages 7 and 8.

Important Information: If the ice maker is installed in a corner, the door may be hinged on the opposite side of the machine, thereby avoiding any interference with a wall.

Important Information: The bottom of the ice maker should be leveled

Important Information: When moving the product with a hand truck or dolly, place the dolly at the side of the product and shut or fix the door tightly to avoid possible opening during movement.

⚠ CAUTION

The finished bottom should be protected with a suitable material to avoid possible damage when moving the product.

Requirements for power supply

120VAC, 60Hz, 15-amp circuit breaker and electric power are required. Additionally, the provided 3-prong power cord should be inserted into a suitable 3-prong, grounded outlet.

Important Information: A Ground Fault Circuit Interrupter (GFCI) is not recommended because the operation of the product may be stopped.

Important Information: The provisions of the National Electric Code as well as any local laws and instructions should be observed when installing the product.

⚠ WARNING

Do not use extension codes or 2-prong adapters. The product should be properly grounded. Do not cut the grounding terminal off the 3-prong plug.

Plumbing Requirements

Connect a 1/4" water line to the water supply.

Install a shutoff valve between the potable water supply and the product so that the user can operate the valve. Do not install the shutoff valve at the back of the product.

Do not use a self-piercing valve. If the water has a high mineral content, a water filter will be required.

The water pressure should be maintained at a level between 20psi and 80psi. The power supply, water line and drain line should satisfy all the provisions under local laws and regulations. For instruction on how to run the water line, refer to the installation specifications and drawings on pages 7 and 8.

Important Information: This product is designed for use in a "built in" application, but it may be required to move the icemaker forward for service. Therefore, do not install anything in front, above or below the product which may act as an obstacle when moving the product.

When leveling the bottom of the ice maker, place shims equivalent to the thickness of the bottom under the product to keep the ice maker and bottom horizontal. The lateral side should have at least 1/6" of space for projection of the screw head.

Installation on a slab: When using the model with a built-in drain pump, the drain pump may pump the water up to about 8ft in height.

The ability to pump the water will be affected by the piping used to do so.

Important Information: Piping should be carried out in accordance with all the provisions laid out under local laws and regulations.

4. Gravity Drain Model

The drain line should drop 1/4" for every foot.

A standpipe fitted with a trap at the lower part may be used as a drainpipe.

Important Information: Installation of an incorrect drain line may cause the ice in the ice bin to melt rapidly.

- 1) Position the ice maker at the front of the opening of the installation location.
- 2) Install the water inlet pipe (1/4" diameter copper pipe) and connect to the water supply valve.
- 3) Run the drain line from the ice maker to the drainpipe. If the horizontal distance is 5' (1.5m) or longer, the drain line should be secured to the wall to the rear of the product.
- 4) Insert the provided plug into the outlet.
- 5) Connect the water inlet line to the water-supply valve of the product.
- 6) Cut the drain tube to the required length.
- 7) Connect to the drain with a 3/4" FPT (NPT) fitting.
- 8) Turn on the water supply and check for any leaks.
- 9) Level the ice maker by adjusting the leveling legs.

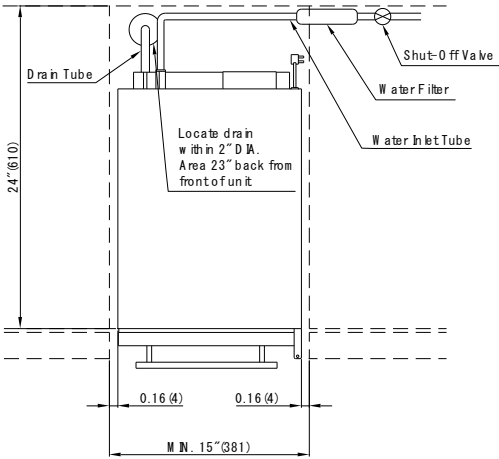

Fig. 4 Top View

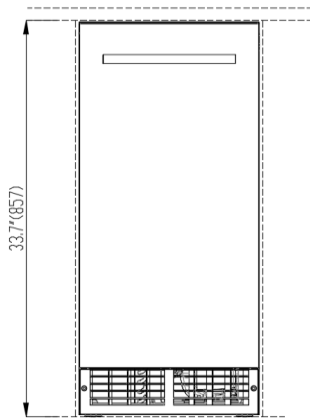

Fig. 5 Front View

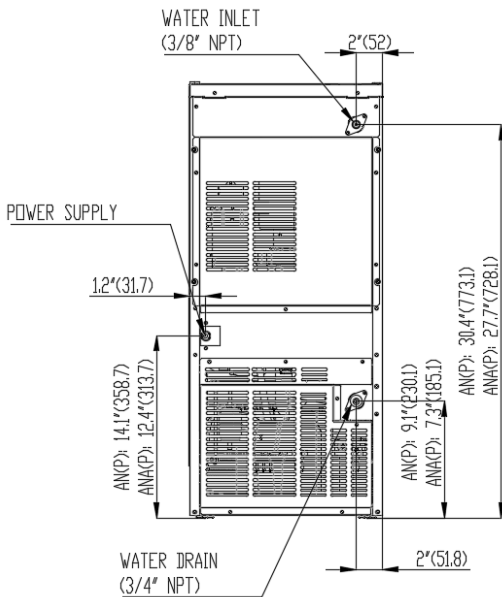

Fig. 6 Rear View

5. Drain Pump Model

- 1) Position the ice maker at the front of the opening of installation location.
- 2) Install the water inlet line (1/4" diameter copper pipe) and connect the water supply valve.
- 3) Connect the drain line from the ice maker to the drainpipe.

Important Information: An air gap may be required between the drain line and the drainpipe, under the provision of local laws and regulations. Refer to the drawing below.

- 5) If the electric outlet is at the back of the product, insert the provided plug into the electric outlet.

- 6) Install the product so that the front of the product is facing forwards.

- 7) Connect the water inlet line to the water-supply.

- 8) Connect the 5/8" drain hose to the drainpipe at the back of the product using a hose clamp. If required, immerse the drain hose in warm water before connecting it to the fitting.

- 9) Turn on the water supply and check for leaks.

- 10) Pour 3 quarters of the water into the ice bin. The drain pump should activate and pump the water upwards. Check the drain pump for proper operation and leaks.

- 11) Turn the switch to the "ICE" position. The compressor starts working 3–5 minutes.

- 12) Pour 3 quarters of water into the ice bin and block the drain tube while the drain pump is operating. At this time, check whether the operation has stopped.

- 15) Adjust the leveling legs.

Important Information: Plumbing should be carried out in accordance with all the provisions laid out under local laws and regulations.

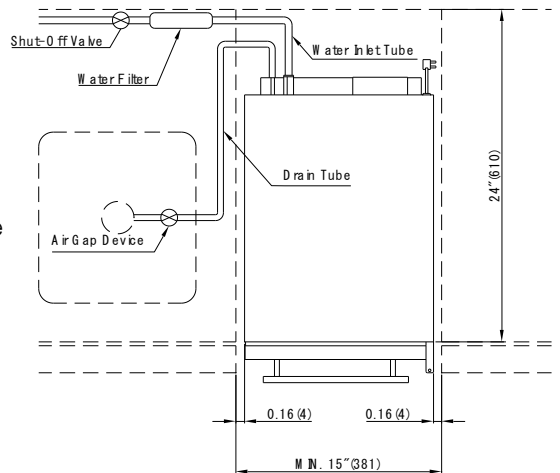

Fig. 7 Top View

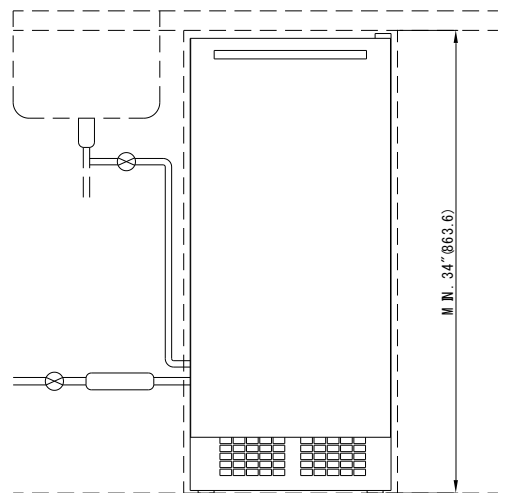

Fig. 8 Front View

Drain pump kit (Optional)

You may order the ice maker with or without a drain pump. In the case of the model with no drain pump, water is drained by gravity.

However, it is possible to install a drain pump kit on the gravity drainpipe model if you wish convert the model to a drain pump model.

You may obtain the necessary parts for conversion from your local distributor.

A detailed description of installation is included in the kit.

6. Installation of the Product

Important Information: Turn on the water supply and check for any leaks at the connection.

The user does not need to fill the container with water. The first batch of ice should be discarded. Ice production requires 1–2 hours.

Leveling legs

Turn the legs counterclockwise to raise the product, or clockwise to lower it.

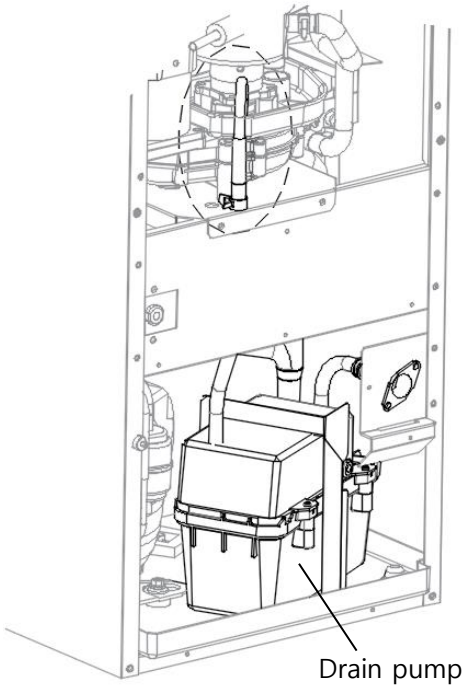

Fig. 9 Joint of air hose

CAUTION

Do not cover the kick plate/grill.

The ice maker is ventilated through the front ventilation panel. A decoration door may be installed on the front, but the ventilation holes of the kick plate/grill should not be blocked.

The kick plate/grill may be painted in another color. Follow the simplified steps outlined below.

- ① Smooth the surface using fine sandpaper.
- ② Scrub the surface until it is clean and dry using alcohol.
- ③ Use a machinery or industrial oil base or gloss enamel paint.

Door Reversal

The direction in which the door opens may be changed.

The hinges are attached to the right-hand side of the door when the product is shipped from the factory. However, the ice maker is designed so that the hinges may be installed on either side. If the hinges are moved to the left-hand side, the door will open to the left.

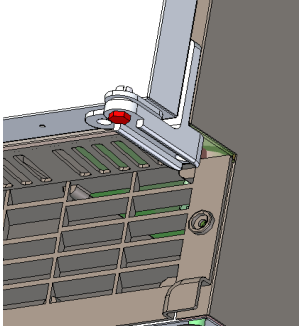

- ① Loosen the anchor screws on the lower hinge of the door and separate the door.

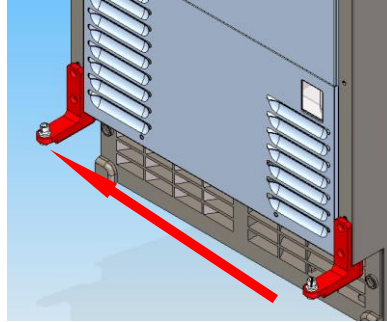

- ② Loosen the anchor screws on the lower hinge and insert the hinge into the hole on the left.

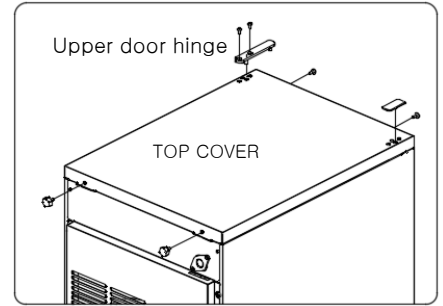

- ③ Release the screws to remove the upper door hinge and upper cover.

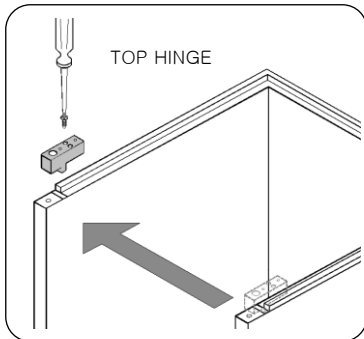

- ④ After removing the top hinge on the right, move it to the left and fasten the screws as shown in the above figure.

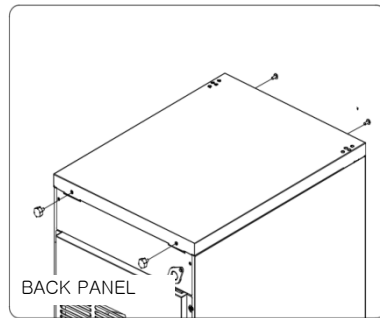

- ⑤ Replace the upper cover and fasten the screws. (four parts at top cover)

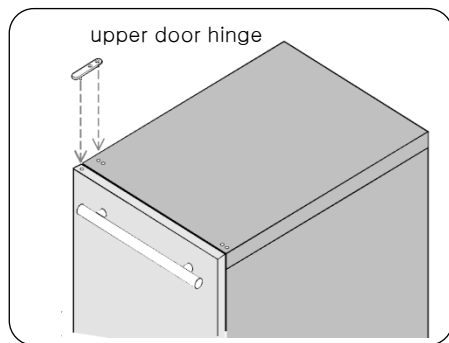

- ⑦ After moving the upper door hinge to the left and inserting it into the hole on the front door, fix it in the hole on the upper cover and fasten the screws (two parts).

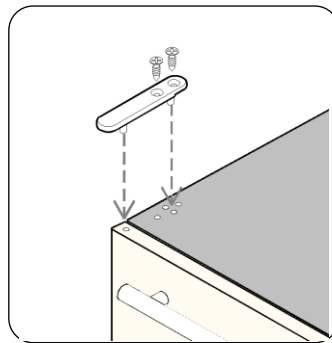

- ⑧ Check the movement of the door by opening and closing it.

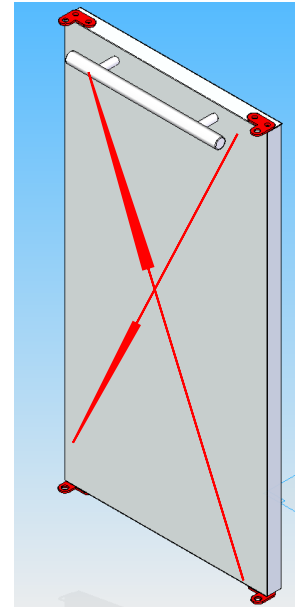

- ⑥ Move the "L" shaped door hinges of the upper and lower parts of the door to the left.

Installation of custom door panel

This description concerns the model on which a decorative door is installed.

- ① Loosen the anchor screws on the lower hinge of the door and separate the door.
- ② Arrange the decorative door so that it matches the door of the product.
- ③ Mark the center point of the top hinge and down hinge holes that extend over the overlay panel. And then drill $3/8"$ diameter holes $1/4"$ deep at that point.
- ④ Remove the overlay panel from the door and tighten the two M4×8 truss head screws securing the sheet metal bracket to the overlay panel.
- ⑤ Separate the inside gasket of the door and fasten it by inserting the four screws into the four holes at the corners..
- ⑥ Fix the supplied door anchor bracket at the lower ends of the door and decorative door.
- ⑦ Fix the completed door on the upper and lower hinge and fasten the anchor screws of the lower hinge.
- ⑧ Check the operation of the door.

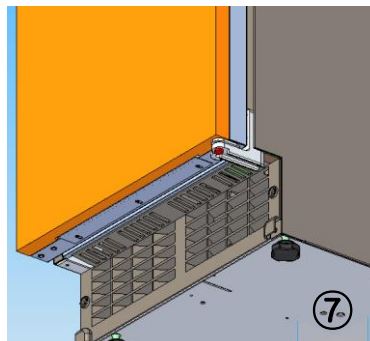
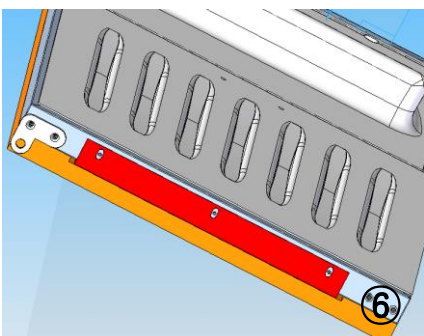
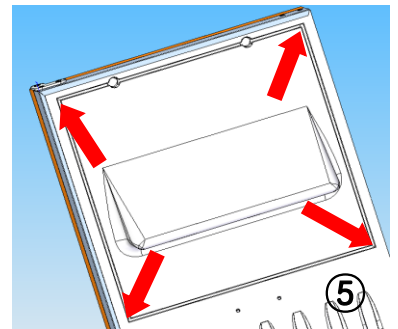
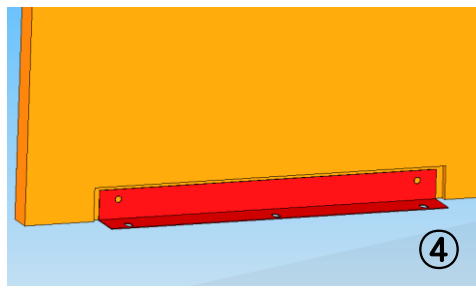
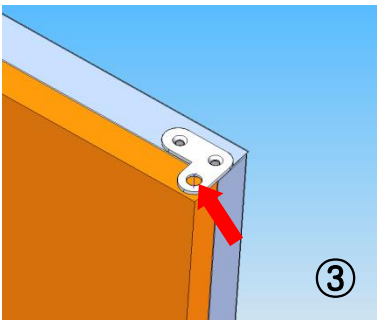
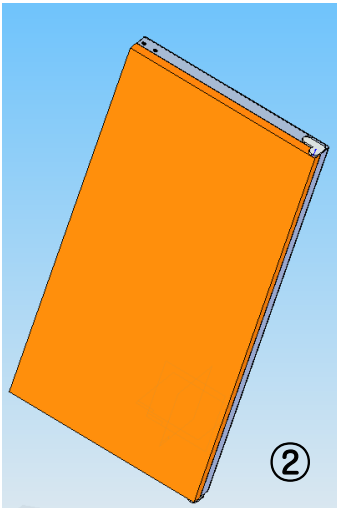
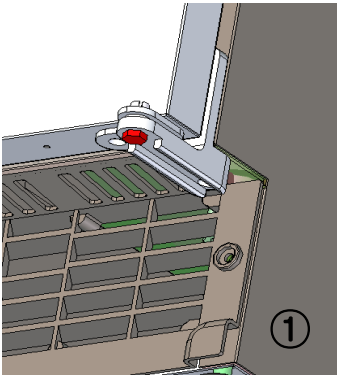

Installation Checklist

If you have any questions or problems regarding installation, address your queries to the distributor or dealer. You may also seek information on the company's website.

- Does the ice maker work properly?
If the ice maker does not work, check whether the plug has been inserted properly.
- Did you remove all the packing materials and tape from the inside of the ice maker?
- Did you observe the instructions on installation?
- Did you level the unit?
- Is the front of the kick plate/grill adequately ventilated?

Used refrigerators and freezers should be safely stored or disposed of. Ensure that the product's door has been removed or permanently closed. If children are able to enter the icemaker, a serious accident may occur.

 **WARNING**

7. Guide to Operating the Ice Maker

Button & Display

LAMP button

- If you open the door, the interior lights turn on done (for 30 seconds)
- Each time you press the button, the light color changes (White, Blue ,Green, Red, Scarlet, Sky blue)

ICE lamp

- When the operation switch is switched to the 'ice' position, this will always come in first. The initial water subtraction is done three times and then the ICE MAKING operation is proceeded.

NO WATER lamp

- When the water supply is not good, the 'LED' turns on

DRAIN lamp

- The 'led' lights up when the drain valve is actuated



Fig. 10 Button & Display

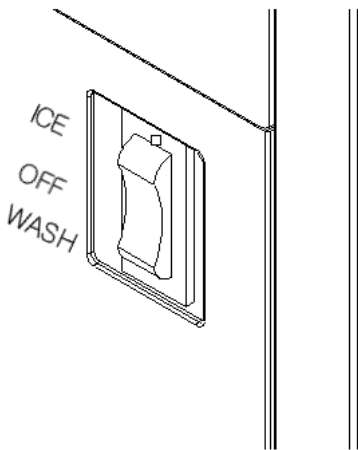
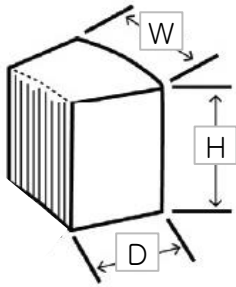

Fig. 11 Operation Switch

Initial operation

- ① Open the water supply valve connected to the ice maker.
- ② Insert the plug of the ice maker into the electric outlet.
- ③ Open the door and turn the switch at the lower end of the product to the "ICE" position."
- ④ Discard the first batch of ice.
- ⑤ Good-quality ice is produced 1-2 hours later.



approximate size in inches, image not to scale

Fig. 12 Ice Nugget

Using the ice maker

Use of the ice maker is very simple. Simply turn the switch at the lower end of the product to the "ICE" position. The product automatically starts ice production, which continues until the ice container has been filled with ice. Remove the ice using indoor ice scoop found on the inside left wall of the icemaker.

When cleaning, the switch must be set to "DRAIN" or "WASH". The cleaning process takes about 10 minutes and performs the following operations.

- ① After water is supplied to the first water tank, the AUGER operates for 5 minutes. At this time, if you want to add the cleaning solution, put it in the ice outlet.
- ② After the above process is complete, drain and re-water.
- ③ After that, operate the AUGER for 1 minute.
- ④ Repeat steps ② and ③ twice more, drain and stop the product.

Important Information: Do not put anything other than ice in the ice bin. Wine or beer bottles are unsanitary and a detached label may block the drainpipe.

Ice container

The product continues making ice until the level of ice reaches the temperature sensing tube (right side). It then ceases operation.

The model with a drain pump drains away melted ice when the ice maker is turned off. The pump works for only several seconds.

Operation time

The machine continues to operate until the ice bin is full, which takes about 10 hours.

Full bin time may vary depending on the ambient and water temperatures.

How it makes ice

Water is supplied to the inside of the drum, and as the AUGER rotates, the water freezes and is ejected upward. Impurities in the water are periodically discharged by the drain valve to create clean ice.

Cleaning

Remove all ice from the storage bin before cleaning the ice maker. Prepare by mixing 0.25ℓ of nickel–safe ice machine cleaner and 5ℓ of water.

1. Open the door and pour approximately 1 liter of cleaning solution into the ice spout.
2. Toggle the lower front mode switch to “DRAIN”.
3. Then, the ice maker automatically cleans, drains and supplies water repeatedly, which takes about 10 minutes.
4. Use a brush or cloth to clean the inside of the reservoir with the remaining cleaning solution.
5. After 10 minutes have elapsed, rinse the inside of the reservoir with clean water and pour water into the ice spout.
6. Toggle the mode switch to "DRAIN" once again.
7. After about 10 minutes, the cleaning processes will have finished.

Sanitizing

Remove all ice from the storage bin before cleaning the ice maker. Prepare by mixing 0.25ℓ of sanitizer and 5ℓ of water.

1. Open the door and pour approximately 1 liter of cleaning solution into the ice spout.
2. Toggle the lower front mode switch to “DRAIN”.
3. Then, the ice maker automatically cleans, drains and supplies water repeatedly, which takes about 10 minutes.
4. Use a brush or cloth to clean the inside of the reservoir with the remaining cleaning solution.
5. After 10 minutes have elapsed, rinse the inside of the reservoir with clean water and pour water into the ice spout.
6. Toggle the mode switch to "DRAIN" once again.
7. After about 10 minutes, all cleaning processes will have finished.

Cleaning outside

If the surface of the door and lever become stained, scrub them at once. If the door and/or gasket have spots on the surface, remove the spots using soap and warm water. Use non-abrasive cloths or pads. In the case of the stainless steel exterior, use a soft and non-abrasive stainless steel washing agent and use a soft lint free cloth.

CAUTION

When performing maintenance work or cleaning, turn off the switch or circuit breaker of the ice maker.

Cleaning the ice bin

The ice bin should also be cleaned regularly. 1 ounce of home bleaching agent and 2 gallons of warm water at 95°F–115°F (35–45°C) are mixed for use as a cleaning solution. Moisten clean cloths with the cleaning solution and scrub the inside of the ice bin with the cloth. Pour a small quantity of the solution into the drain Pipe, then dry the interior.

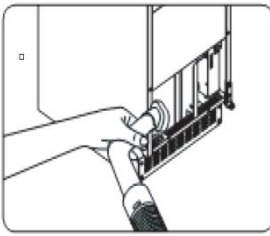
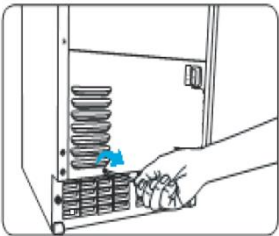

Cleaning condenser

The condenser should be cleaned 2–3 times a year to remove any lint that has penetrated the condenser. When cleaning the condenser, remove the front lower panel and the kick plate/grill using a screwdriver. Then, remove any dust and lint from the condenser using a soft bristle brush. For the position of the condenser, refer to the drawing.

Important Information: To avoid possible bending of the condenser fins, clean the condenser in the direction of the fins (up and down).

CAUTION

If the condenser is not cleaned, the temperature may rise or the machine may experience technical problems or sustain damage.

8. Maintenance Schedule

- The following maintenance schedule is guideline
- Maintenance and repair should be done more frequently according to water quality, equipment usage environment and local hygiene regulations.

Maintenance Schedule		
Frequency	Area	Task
Daily	Scoop	Clean the scoop using a neutral cleaner. Rinse thoroughly after cleaning.
Monthly	External water filter	Make sure that the pressure is adequate and make changes if needed.
	Outside of the ice maker	Wipe down with clean, soft cloth. Use a damp cloth containing a neutral cleaner to wipe off oil or dirt build up. Clean any chlorine staining (rustcolored spots) using a non-abrasive cleanser.
	Storage Bin, Inner door, Ice outlet(Spout)	Wipe clean with clean cloth and warm water.
Every 6 Months	Icemaker and Storage Bin	Clean and disinfect according to the disinfection instructions given in the instruction manual.
	Evaporator Condensate Drain Pan and Gear Motor Drain Pan	Wipe down with clean cloth and warm water.
	Ice maker and reservoir	Always check that it is kept clean.
	Ice exit fixing seal bolt	Check for leaks around the seal bolt. Tighten if necessary and replace O-rings. Always replace the O-ring when loosening the seal bolt and tighten it again. If there is no O-ring, apply Loctite 243 or equivalent fixing agent so that it does not leak.
Yearly	Water supply valve and Drain valve	Close the shutoff valve to shut off the water supply line and drain the water. Close the shutoff valve to shut off the water supply line and drain the water.
	Water hose	Check the water hose and clean it if necessary.
	Condenser (air-cooled)	Inspect for cleaning. If necessary, clean with a brush or vacuum cleaner If the dust adhesion is severe, spray the pin cleaning agent, clean the dust, spray it with clean water, rinse and dry with air gun.
	Ice maker	Inspect for oil marks, loose components, tightening parts and wires.
	Upper bearing (Ice exit head)	Check that 0.02" round bar or pin gauge (or clearance gauge) is inserted into auger and bearing clearance, and replace all upper and lower bearings (ice exit head and lower housing)
	Mechanical seal	Check for leaks in the bottom housing, and if there is a leak, disassemble the auger to replace the mechanical seal. (Water with a lot of calcium will shorten the life of replacement parts.)
After 3 Years, then Yearly	Upper and lower bearings, Housing O-ring, Mechanical seals, Evaporator cylinder, Auger	Please check. If the auger and bearing clearance exceeds the factory recommended value (0.02" or less), replace both the upper and lower bearings. If the contact surface of the mechanical seal is worn, cracked, or scratched, replace it.

9. Specifications

Items		Specification	Remarks
Model		IU-0090-AN, IU-0090-ANP IU-0090-ANA, IU-0090-ANAP	~P: W/D Drain Pump
Ice shape		Nugget	
※ Maximum sapacity (at air 50°F, water 50°F)		88 lb/day (40 kg/day)	
Storage capacity		24.3 lb (11 kg)	
※ ※ Size (WxDxH)		AN~ : 14.9" x 21.9" x 34" (378 x 556 x 858 mm) ANA~ : 14.9" x 21.9" x 32" (378 x 556 x 813 mm)	
Power supply		AC 115V 60 Hz, 1PH	
Current consumption		3.3 A	
Weight	Before packing	112±11lb (51±5 kg)	
	After packing	187±11lb (85±5 kg)	
Compressor		510W	
Condensation method		Air-cooled	
Refrigerant		R-134a	
Geared motor	Power supply	AC 115V 60 Hz, 1PH	
	Rated output	40W	
Installation environment standard	Ambient temperature	50 ~ 100 °F (10 ~ 38 °C)	
	Supplied water temperature	50 ~ 80 °F (10 ~ 32 °C)	
	Water pressure	20 ~ 90 psi (0.1 Mpa ~ 0.5 Mpa)	

10. Error Type

Current Condition	Lamp			Causes	Action / Release
	● ICE	● NO WAER	● DRAIN		
Ice Making	L			When the operation switch is switched to the 'ICE' position	
Washing	B			When the operation switch is changed to 'WASH', the 'ICE' lamp blinks (every 1 second)	Drainage stops and goes out when the operation switch is switched to the 'off' position
Ice Full (Storage bin)	B			When the storage bin is full of ice (Lights on every 2 seconds, turns off for 1 second repeatedly)	When the ice full sensor detects the release temperature, the lamp turns off
Drain valve operating			L	When the drain valve opens	
Water supply error		B		When water level is not detected by the water level sensor due to no water supply for 2 minutes.(Er15)	Water supply pressure check Water level sensor check Start operation after action
Water drain error			B	If the lower limit water level sensor is not detected within 2 minutes as the drain valve operates(Er16)	Replacement of water wevel wensor Check drain valve operation Start operation after action
Evaporator temperature error	B	B	B	When the Evaporator temperature is 32°F or more after 30 minutes passed during the ice making(Er01)	Check refrigerant leakage Check sensor and attachment abnormality Resupply power after resolving cooling problem
Evaporator temperature error	B			When the Evaporator temperature is 32°F or more after 10 minutes passed during the ice making(Er03)	Check refrigerant leakage Check sensor and attachment abnormality Resupply power after resolving cooling problem
Ice full sensor error		B	B	When the ice full temperature sensor in the storage bin is disconnected or shorted	Check sensor and attachment abnormality Start operation after sensor part repair
Evaporator temperature sensor error	B	B		When the EVA temperature sensor at the evaporator outlet is disconnected or shorted	
Air temperature sensor error	B		B	When the air temperature sensor in front of the condenser is disconnected or shorted	
Evaporator freezing	L	L	L	When the evaporator outlet temperature drops below the set temperature for 2 minutes while the ice maker is running(Er25)	Occurs when the ambient temperature is low Operate when the ambient temperature is over 50°F

* L: Lamp On, F: Lamp Blinking

11. Circuit diagram

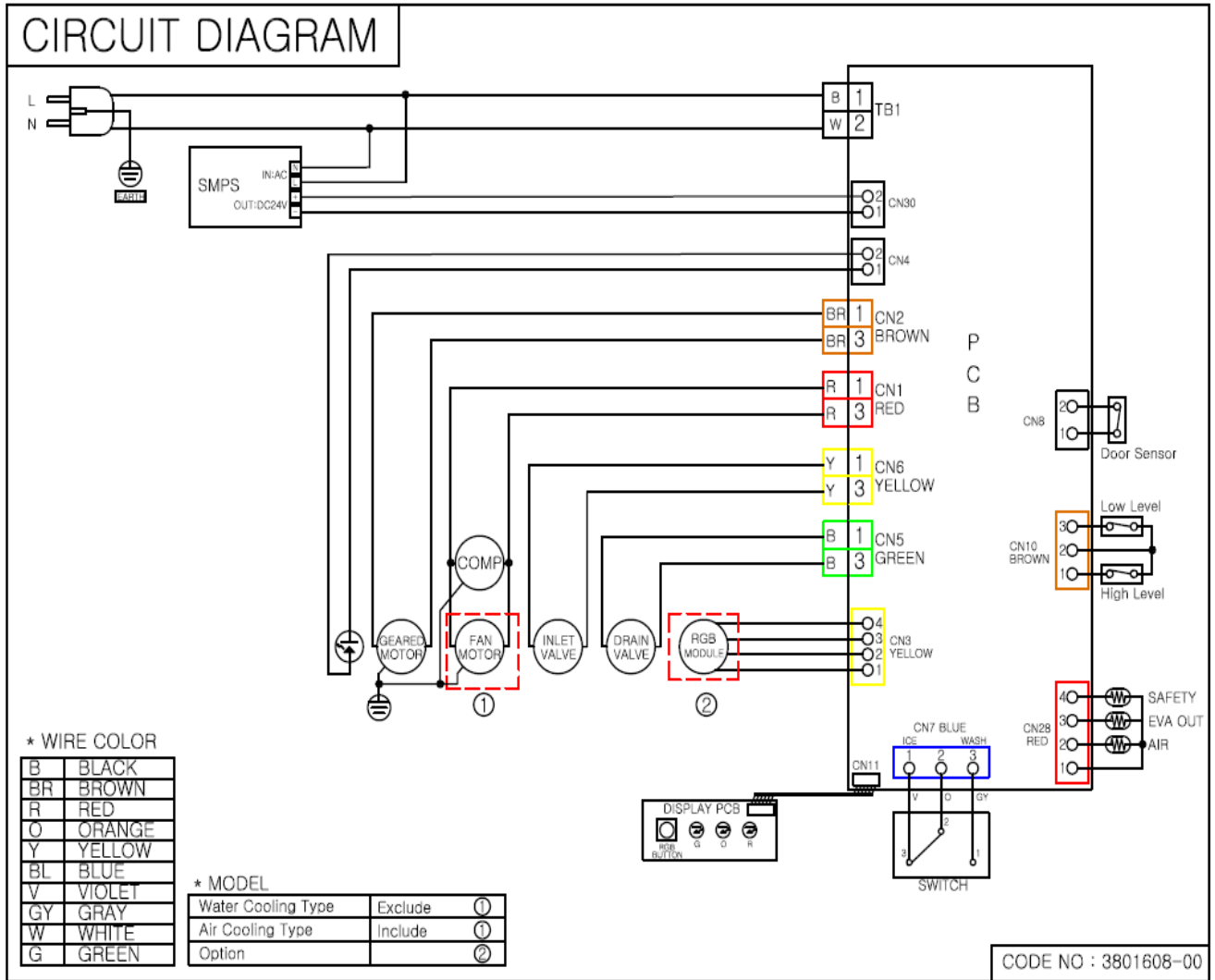

12. Troubleshooting guide

PROBLEM	POSSIBLE CAUSE	POSSIBLE SOLUTION
Ice maker does not operate	Ice maker is unplugged	Plug ice maker in.
	Breaker tripped	Reset breaker – if it happens again, call an authorized service contractor.
	Switch turned to “OFF”	Turn switch to “ICE”.
	Storage bin full, keeping ice maker off	Ice on sensor tube – it is normal for ice maker to be off. Ice maker in room below 50°F (10°C) – room must be warmer for ice maker to operate.
	Drainpipe blocked (Drain pump model)	Clean out the drainpipe.
	Drain pump not working (Drain pump model)	Check the drain pump. Call an authorized service contractor.
Ice cubes are too large	Cube size control set too cold	Call an authorized service contractor.
Quality of ice inconsistent	Not enough water	Check water supply – filter may be restricted. Check inlet water valve – inlet screen may be restricted.
	Cube size control set too warm	Call an authorized service contractor.
Makes a sound when making ice	There is a lot of scale inside the drum	Clean ice making system with ice machine cleaner.
Ice maker makes ice, but storage bin does not fill with ice		
	Storage bin drain may be partially restricted	Clean out drain, check installation.
Ice cubes are partially formed – white at the bottom	Possible scale in evaporator	Clean evaporator with ice machine cleaner.
Unit operates but no ice falling in storage bin	Ice may be stuck in the evaporator and the unit is “frozen up”	Check water supply – filter may be restricted. Check inlet water valve – inlet screen may be restricted or valve does not operate. Hot gas valve may not operate – check and repair or replace.
	Water temperature too high	Inlet water valve leaks through, must be replaced.
	No airflow	Fan motor does not operate or fan blade is broken, must be replaced. Condenser completely blocked, must be cleaned.
	Compressor does not operate properly or at all	Call an authorized service contractor.
	Not enough refrigerant	Call an authorized service contractor.
	Hot gas valve leaks through	Call an authorized service contractor.

Service Information

To request service, you should know the model and serial number of the ice maker. You can find the model and serial number printed on the label on the front of the product after opening the door. To receive the warranty service, you should know the date of installation and the distributor it was purchased from. Record this information for future reference.

Model number:

Serial number:

Date of installation:

A/S center of ICETRO and telephone number:

Distributor of ICETRO and telephone number:

Before requesting the service

Before requesting service, refer to the troubleshooting guide on pages 19. Check whether the fuse has been cut or tripped by inspecting the home fuse and circuit breaker. Check whether the power has been disconnected. Operation of the product may cease in the event of a power failure.

The information and images included in this guidebook are the property of ICETRO. It is not permitted to copy or use a part or the whole of this manual and the information and images included in this manual without first obtaining written approval from ICETRO.

